

TOGGLE-LOCK™

GRAVITY OUTLET GATE for COVERED HOPPER CARS

- Proven Design
- Rapid-Action Self-Locking Door
- Free-Drop Interior Surfaces
- Full Self-Clearing Action
- No Secondary Lock Required
- No Racks or Pinions to Jam or Wear
- No Ledges or Shoulders to Retain Lading
- Easy to Remove, Replace or Maintain
- Easy and Safe to Operate
- Sturdiest, Most Reliable Gate Available

Details:

Nominal Size:	13 x42
Working Points:	27 1/8 x 62 3/4
Application:	Bolt-On, 32 Hole
Slope	Flanged
Weight	472 Lbs.



IN USA AND MEXICO, SOLD BY:
 UNITY RAILWAY SUPPLY CO., INC.
 805 GOLF LANE PHONE (630) 595-4560
 BENSENVILLE, IL 60106 FAX (630) 595-0646

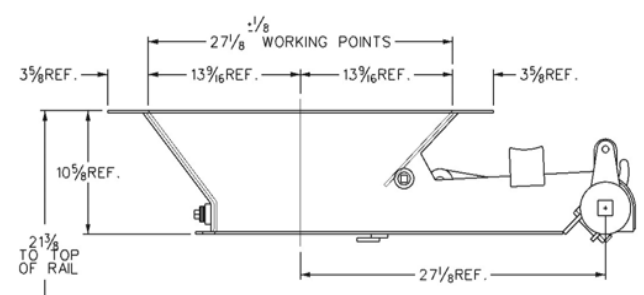
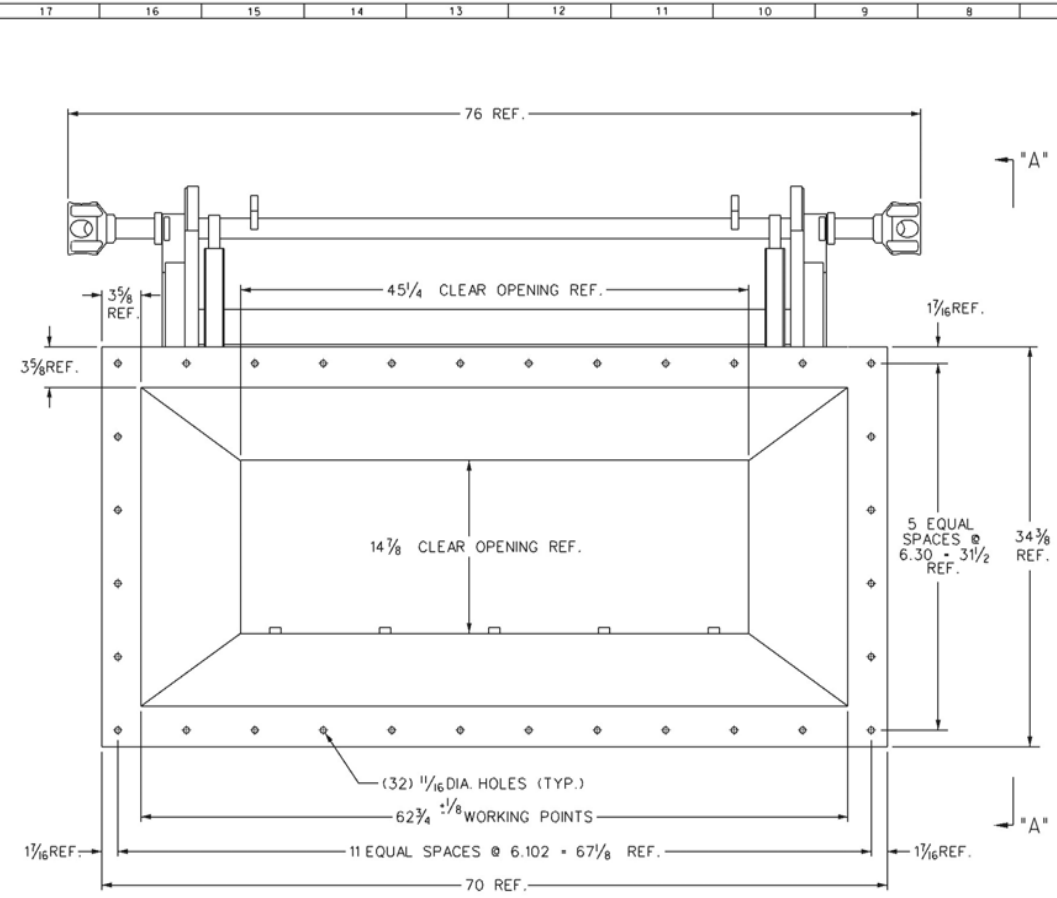

VIEW "A-A"

PART NUMBER: 04A

- NOTES:
- 1.) GATE TO BE SUPPLIED UNCOATED.
 - 2.) MATERIAL THICKNESS : GATE PLATE 3/8;
FRAME CONSTRUCTION 1/4.
- WEIGHT: 472 LBS.

DAVANAC INC.
 1936 ST-RÉGIS
 DORVAL, QC H9P 1H6

TOGGLE-LOCK™ OUTLET
 GATE (PRODUCT 04A)
 (WORKING PTS. 27 1/8 X 62 3/4)

SCALE: N.T.S. DATE: MARCH 28, 2003

SALES DRAWING NO. REVISION

DAV-04A A

SIZE D DR. DRE REDR: CHK. 7-29-04

• SUBJECT TO CHANGE
 WITHOUT NOTICE

DRAWING TOLERANCES:	ALL INFORMATION CONTAINED IN OR DISCLOSED BY THIS DOCUMENT IS CONSIDERED CONFIDENTIAL AND PROPRIETARY BY DAVANAC INC. ALL DESIGN, MANUFACTURE, USE, REPRODUCTION, AND ALL SALES RIGHTS ARE EXPRESSLY RESERVED BY DAVANAC INC. AND COMMUNICATION OF THIS INFORMATION TO OTHERS IS PROHIBITED WITHOUT THE PRIOR WRITTEN CONSENT OF DAVANAC INC.
ALL DIMENSIONS ARE IN INCHES UNLESS OTHERWISE SPECIFIED.	
FRACTION DIMENSIONS: ± 1/4	
ANGULAR DIMENSIONS: ± 1°	